

TB260



POWERFUL
COMPACT
EXCAVATOR

TAKEUCHI
Japanese for reliability

Takeuchi's New 6 tonne Excavator - brings powerful excavating and breakout force in a compact machine size

Takeuchi introduces a 6 tonne (5660kg) category of excavator with the new TB260. It's not just an expanded 5 tonne TB250, or a reduced down 8.5 tonne TB285, the new TB260 is the first ever 6-tonne excavator from Takeuchi and provides a powerful addition for this in-demand weight class.

The TB260 combines all the proven characteristics of Takeuchi excavators - smooth hydraulics, powerful machine performance and good serviceability.

The new model is part of Takeuchi's on-going commitment to machine development, environmental efficiency, operator comfort, safety and improved machine ergonomics.

The new TB260 has plenty of power and greater torque along with a well proven, high performance hydraulic system for greater oil flow for faster cycle times and increased efficiency.



POWERFUL BREAKOUT FORCE & INCREASED REACH

Powered by a Yanmar 4TNV84T turbocharged engine, the environmentally friendly diesel engine is fuel efficient - with automatic idle, dial throttle control with economy work-mode and electronic engine monitoring.

The TB260 features 43.2 kN bucket breakout force and 27.3 kN digging arm force - high power for a 6 tonne excavator.

With a massive ground reach of 6130mm and dig depth of 3895mm the new TB260 offers lots more on site.

MAXIMUM OPERATING PERFORMANCE

With a track footprint of just 2000 x 2575mm, the new TB260 with its compact size gets maximum accessibility on restricted sites.

Two-speed tracking with auto step down when dozing.

Boom and arm holding valves minimise cylinder drift and helps maintain load control in the event of a hose failure.

The lift alarm can be turned off when not needed but provides an audible warning when the boom is reaching hydraulic lifting capacity.

Automatic idle reduces fuel consumption with less noise and longer engine lifetime.

The auxiliary detent switch prevents less operator fatigue when using continuously operating attachments. Dual proportional control as standard.

A heavy duty dozer (430mm high) with increased operating range comes as standard for efficient on-site finishing and grading with a well protected cylinder.





BUILT FOR SITE

The TB260 is built for site, with a strong cast steel wraparound and 100% steel panels. Well positioned hydraulic hoses minimize potential damage and are well protected. Tough components and heavy duty design adds to durability.



REDUCED TAIL SWING

The compact TB260 features a shorter than average tail swing compared to conventional 6 tonne excavators. Just 1300mm tail swing radius combined with maximum 300mm overhang at 90° to track, rounded corners and enhanced all round visibility, helps minimise potential machine damage in restricted areas.



RELIABLE TRACK DESIGN

Triple flange rollers and maintenance free bearings add to tracking performance, built for rough terrain to provide many hours of continuous service.





MAXIMUM ALL DAY COMFORT WITH A HIGH VISIBILITY CAB

The TB260 has the operator in mind, the large comfortable isolated cab minimises the impact felt. With a sliding 10-way adjustable suspended seat, headrest and ergonomically positioned hand and foot controls, plenty of foot room, high capacity automatic climate control, heater and defrost options.



The TB260 offers operators excellent all round visibility; work lights as standard, a retractable front window with a removable lower window section, a large skylight with sun shade and a rainguard for a dryer working environment.

A well positioned colour visual display unit illuminates active operating switch functions; lift overload, power altitude, auto idle and auxiliary detent. Operators can easily select auxiliary preset modes to match all types of attachments.

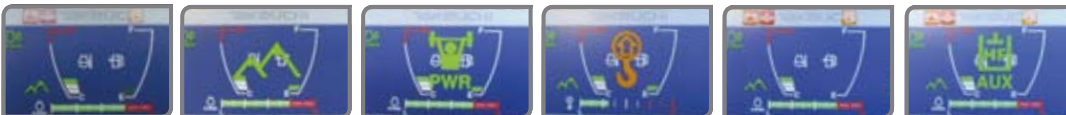

TB260 SERVICEABILITY

The new styled engine hood and side cover provide unparalleled access to engine and hydraulic components simplifying all aspects of machine maintenance - all accessible at ground level.

- Well positioned hydraulic and fuel tank gauges and hydraulic control valve.
- Easy access electric refuelling pump as standard with auto shut off, stowed in own compartment.
- The rear bonnet provides access to the engine service points.
- Automatic fuel bleed system.
- Side-by-side radiator and hydraulic oil cooler ensures fresh cool air reaches each cooler, improving efficiency and component life. The A/C condenser is mounted on a hinged frame - decreasing inspection and cleaning time.



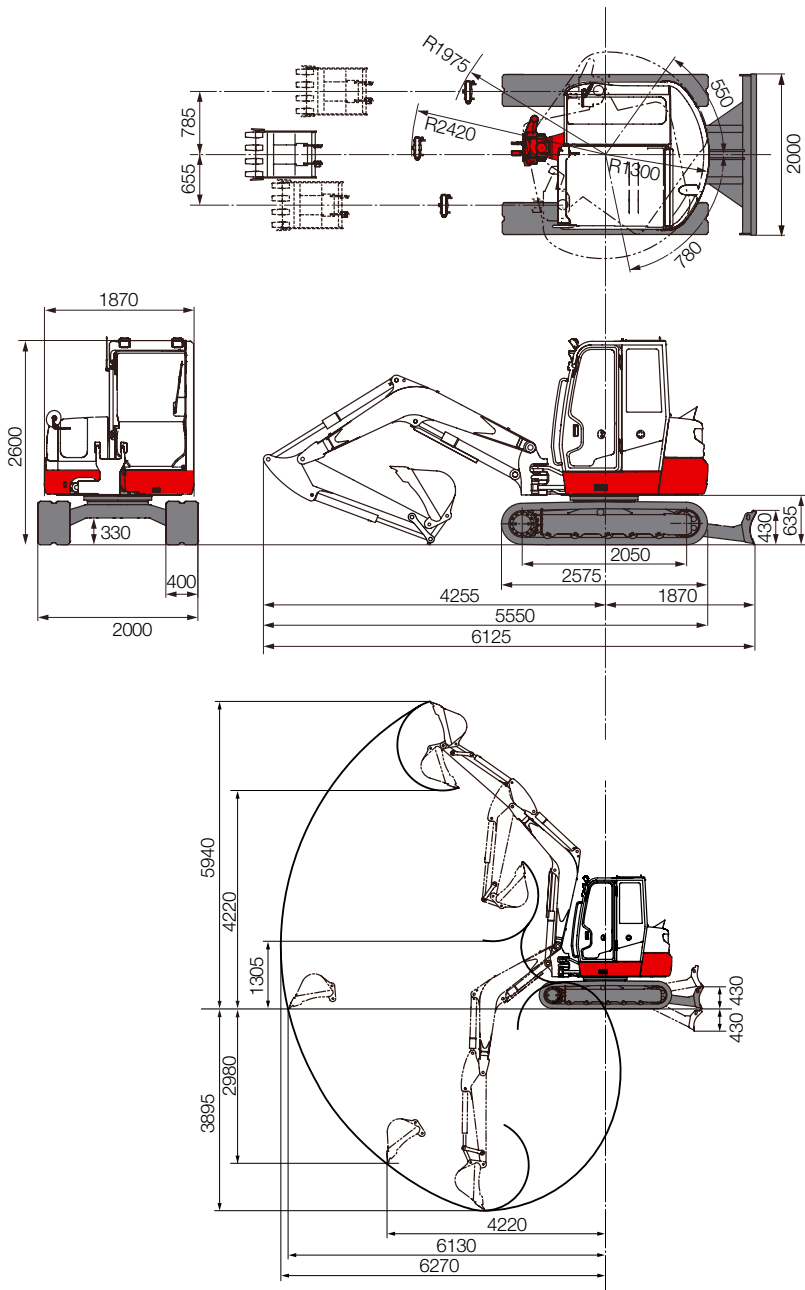

TB260

Standard UK Specification - Long Dipper/Rubber Tracks

Engine	
Make	Yanmar
Model	4TN84T-BPTB
Rated Output (kW)/rpm	34.3 / 2400
Maximum Torque (Nm)	160
Cylinders	4
Displacement (cc)	1995
Electrical System	12volts 90amp

Dimensions & Weight	
Operating Weight inclusive of bucket and fuel (kg)	5720
Length (Transporting) (mm)	5550
Width (mm)	2000
Height (mm)	2600
Ground Clearance (mm)	330
Min. Front Swing Radius (mm)	2420
Slew Radius (mm)	1300
Dozer Blade (W x H) (mm)	430 x 2000

Operating Information	
Max Digging Depth (mm)	3895
Max Dump Height (mm)	4220
Max Reach at Ground Level (mm)	6130
Max Vertical Digging Depth (mm)	4220
Max Bucket Digging Force (kN)	43.2
Max Arm Digging Force (kN)	27.3

Hydraulic System	
Set Pressure (bar)	240
Pump Type Displacement	Displacement
Hydraulic Flow Aux port / Hi-flow	57/100 (l/min)

Swing System	
Boom Swing Angle (L/R)	78°/55°
Slew Speed (rpm)	9.4
Slew Motor Piston	Constant Volume Piston
Slew Brake	Wet Friction Plate

Undercarriage	
Traction Motor	Axial Piston
Traction Drive	Planetary
Traction Brake	Disc
Track Width (mm)	400
Ground Contact Length (mm)	2050
Ground Pressure (kpa)	31
Travel Speed (K/ph)	2.8-4.9
Maximum Gradeability	30°

Capacities	
Hydraulic System (l)	90
Fuel Tank (l)	81
Engine Lubrication (l)	7.4
Cooling System (l)	11

For more information locally
call us direct, or contact:

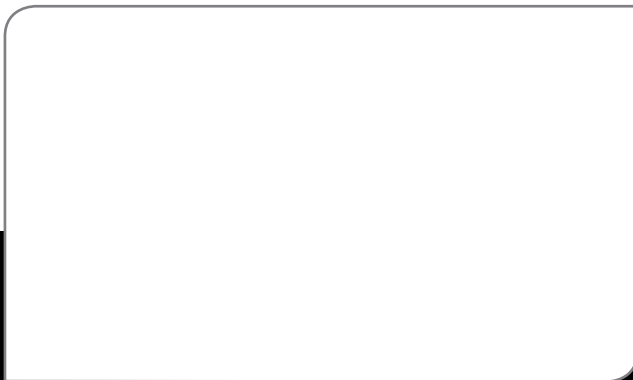

OPTIONS: Steel Tracks, Hydraulic Breaker, Travel Alarm, Hydraulic Quick Hitch.

All dimensions unless otherwise stated are in millimetres.

09/2013

Takeuchi machines come with a 2 year/2000 hours warranty as standard. Warranty exceptions to 1 year; fuel injection systems, electrical components, paint work.

In accordance with our established policy of constant improvement, we reserve the right to amend these specifications at any time without notice. Photographs shown may feature non-standard equipment.

Takeuchi Mfg (UK) Ltd, Unit E2B Kingsway Business Park,
John Boyd Dunlop Drive, Rochdale, Lancashire OL16 4NG
Tel: 01706 657 722 Fax: 01706 657 744

Southern Depot at 20 Colthrop Business Park
Colthrop Lane, Thatcham, Newbury, Berks RG19 4NB
Tel: 01635 877 196 Fax: 01635 877 195

www.takeuchi-mfg.co.uk Email: sales@takeuchi-mfg.co.uk

TAKEUCHI
Japanese for reliability